

DualMEMS Temperature Sensing Technology

SiTime's Elite Platform™ of oscillators and Super-TCXO™ families are based on a novel architecture consisting of a DualMEMS™ die and a mixed-signal CMOS IC with a proprietary temperature compensation scheme and a low-noise frequency synthesizer. This architecture enables excellent dynamic performance, ultra-low jitter, a wide frequency range and programmability. With DualMEMS technology, SiTime has leveraged the company's vast MEMS design and fabrication expertise and an understanding of silicon as a thermal, mechanical, and electrical material to produce the world's most accurate temperature sensor, resulting in OCXO-like performance with a much lower cost, lower power TCXO implementation. Fundamentally, it is the unique DualMEMS die construction that enables exceptional frequency stability over temperature and robustness to dynamic thermal disturbances. Quartz crystal based TCXOs are not capable of matching the stability and resiliency of DualMEMS Super-TCXO devices.

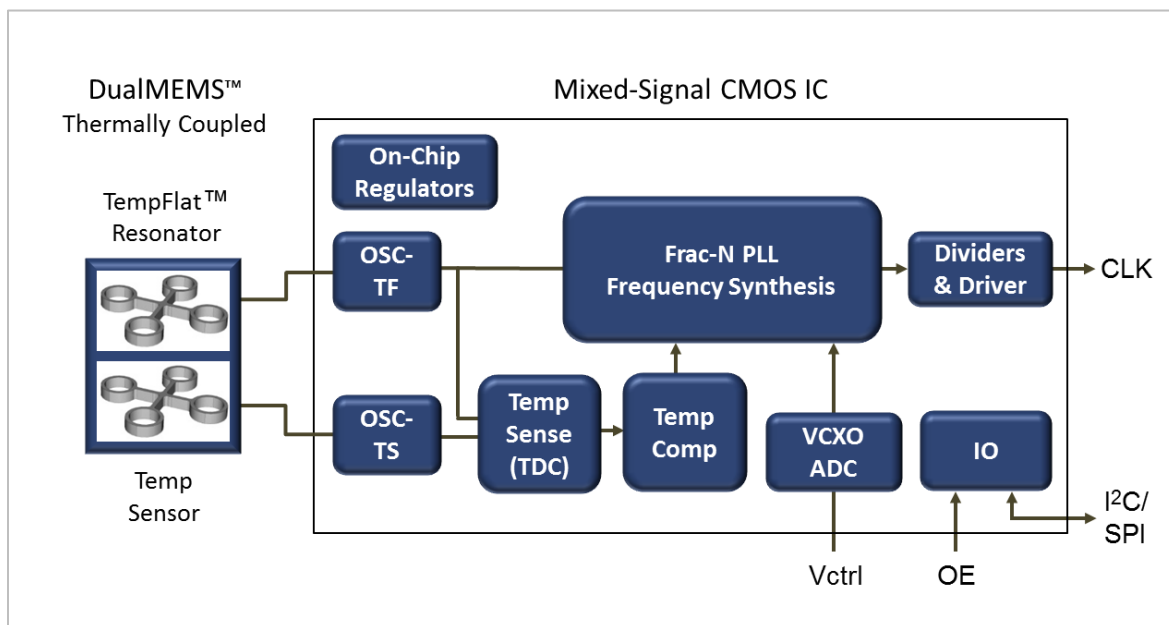

Figure 1: Elite Platform Architecture

DualMEMS technology uniquely allows for co-fabrication of two silicon MEMS resonators within a single die. One resonator is designed using SiTime's TempFlat™ MEMS technology to achieve a flat frequency response over temperature. Without compensation circuitry, TempFlat MEMS alone dramatically improves the uncompensated frequency stability of the silicon MEMS oscillator to less than ± 60 ppm over temperature from -40°C to $+85^{\circ}\text{C}$. The TempFlat-MEMS-enhanced frequency stability over

temperature, which is two times better than quartz crystals, eliminates the need for temperature sensors and external compensation circuitry for some applications. For applications like cloud servers and telecom base stations that require better frequency stability, TempFlat MEMS greatly simplifies the required compensation circuitry and reduces overall system size, power, and cost. The second resonator in the DualMEMS die is designed to act as an extremely accurate temperature sensor. Its frequency is sensitive to temperature changes and has a linear slope of $\approx \pm 7$ ppm/ $^{\circ}\text{C}$. The ratio of frequencies between these two resonators provides an extremely fast and accurate reading of the resonator temperature with 30 μK resolution and bandwidth that runs at 100s of Hz. The temperature reading is used as an input to the temperature compensation algorithm employed in the mixed-signal CMOS IC. Ultimately, the temperature compensated frequency shift of the Elite Platform Super-TCXO is reduced to less than ± 1 ppm between -40°C and $+85^{\circ}\text{C}$.

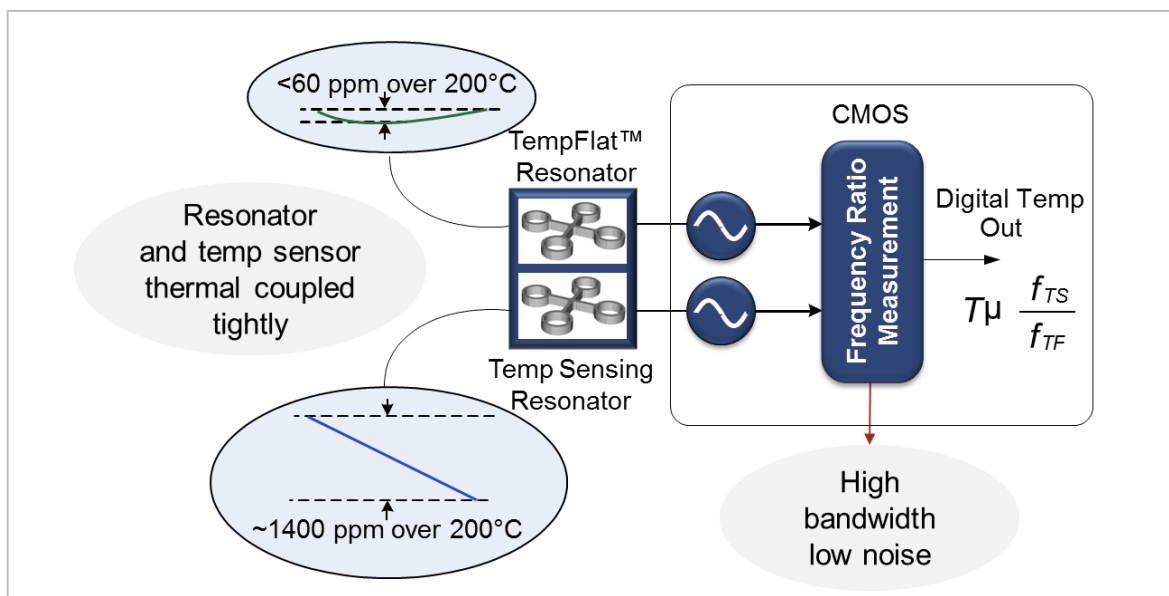

Figure 2: DualMEMS resonators temperature sensing with <30 μK resolution and noiseless temperature compensation

In the DualMEMS construction, the TempFlat MEMS resonator and the temperature sensor are nearly perfectly thermally coupled because they are located as physically close to each other as possible, with only 100 μm separating the two elements. Additionally, the timing resonator and the temperature sensor resonator are thermally shunted through silicon, which is an excellent conductor of heat. This design greatly reduces the time constant for heat transfer between the TempFlat™ resonator and the temperature sensor. Silicon MEMS microfabrication enables both the TempFlat™ resonator and the temperature sensor resonator to have identical construction with the same (very small) mass and equivalent thermal paths to the environment so that they raise and lower their temperature together, with almost no lag. Any temperature lag that does occur (e.g. due to application of some asymmetrical heat flux) will settle to its steady-state condition very quickly.

Video: Comparative dynamic performance of quartz vs. MEMS TCXOs



[Watch dynamic performance](#) of an Elite Platform Super-TCXO compared to 50-ppb quartz TCXO under airflow, temperature ramp, tap test, and VDD fluctuation.

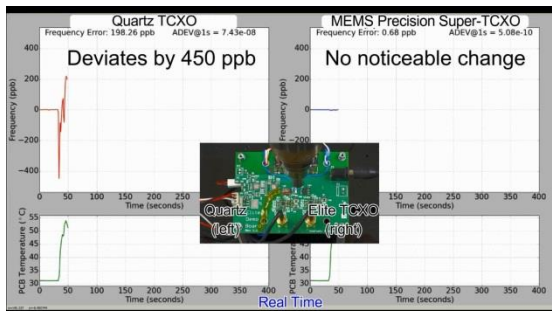

Quartz TCXO performance is fundamentally hindered by the use of a discrete temperature sensor. The lack of thermal coupling between the quartz crystal resonator and a separate temperature sensor makes it impossible to design a fast temperature compensation loop and eliminate thermal gradients without causing loop stability issues and performance problems. As a result, quartz-based TCXOs typically have compensation bandwidth of 5 to 10 Hz, too slow to track rapid temperature changes, causing abrupt frequency jumps when the quartz TCXO is subjected to airflow and/or temperature perturbation.

In contrast, quartz TCXO architectures use an external CMOS IC with a temperature sensor (e.g. a BJT bandgap temperature sensor or a thermistor) and compensation circuitry that is mounted in a ceramic package a large distance away from the quartz crystal. As a result, quartz TCXOs suffer from weak thermal coupling between the resonator and the temperature sensor. Consequently, there is a temperature lag between the crystal and the temperature sensor when the part is subjected to a rapidly varying thermal disturbance. The large temperature offset between the crystal and the temperature sensor leads to application of an errant coefficient in the temperature compensation scheme, which produces a frequency shift of the output clock away from the desired frequency. Moreover, the frequency offset caused by the thermal event will linger for a long time as the crystal and the sensor, respectively, settle to their steady-state temperature values. In fact, fluctuations in output frequency are commonly observed in systems when quartz TCXOs are subjected to thermal disturbances such as turning on a fan for convective cooling or powering on an adjacent system component that dissipates a significant amount of heat.

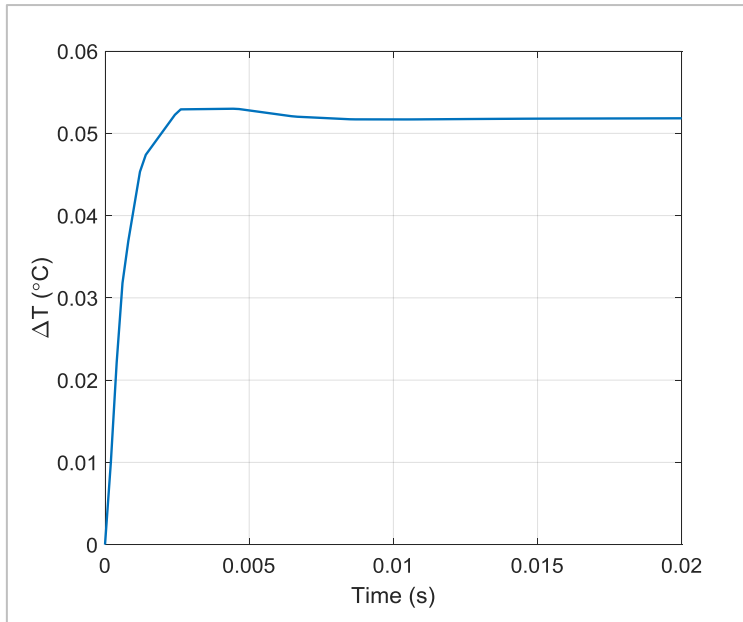

Figure 3: Temperature difference between the TempFlat timing resonator and the temperature sensor resonator employed in the DualMEMS die construction with a convective heat flux incident on one side. Only a 52 mK temperature offset is observed, and the system settles to this value in less than 10 ms.

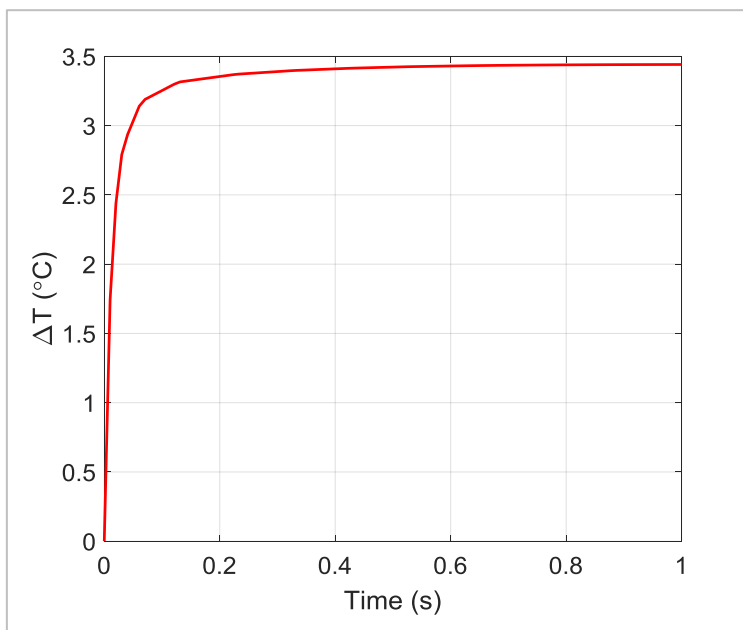

Figure 4: Temperature difference between the quartz crystal resonator and the CMOS die with the temperature sensor with a convective heat flux incident on top of the quartz crystal. Nearly a 3.5K temperature offset is observed, and the system takes nearly a full second to settle to this value.

Thermal simulations performed in Comsol Multiphysics® validate the inherent superiority of the DualMEMS die construction. Figure 3 shows the temperature offset between the TempFlat resonator and the temperature sensor during application of convective heat flux incident on one side of the DualMEMS die. This highly asymmetrical heat flux presents a worst case scenario for the DualMEMS-based device because the imposed heat source is much closer to one of the resonators so that a thermal gradient (albeit small) is forced between the TempFlat resonator and the temperature sensor resonator. In real scenarios, the heat flux would be incident on all sides so that the two resonators are heated symmetrically. Nevertheless, the DualMEMS construction is still shown to be very resilient to thermal disturbances. In this example, shown in Figure 3, the heat flux produces only a 52 mK deviation in temperature between the TempFlat and temperature sensor resonators, and the temperature settles to its steady-state value after less than 10 ms. Quartz-based oscillators, however, are not as robust when subjected to the same heat flux incident on top of the quartz crystal. Figure 4 demonstrates that the temperature offset between the quartz crystal and the CMOS IC with the temperature sensor is much larger, almost 3.5K, and it takes nearly 1s to settle to this value. Clearly, the results show that the thermal performance of the Elite Platform DualMEMS architecture is orders of magnitude better than a typical quartz TCXO.

Quartz oscillator package construction

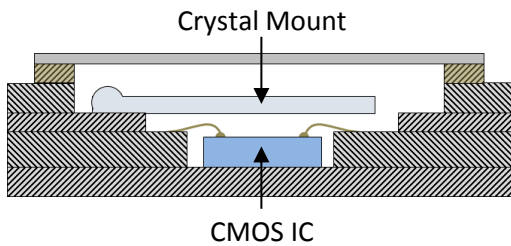

Figure 5a: All-in-one quartz oscillator package cross-section (de-capped)

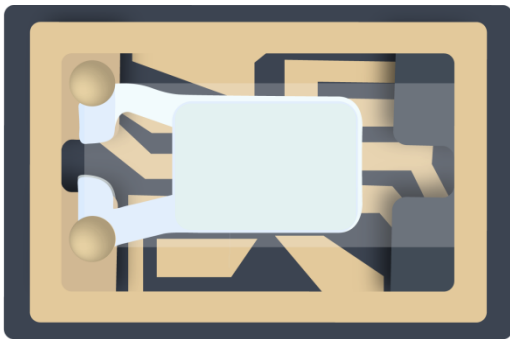

Figure 5b: De-capped quartz TCXO in a ceramic package with the crystal mounted on top

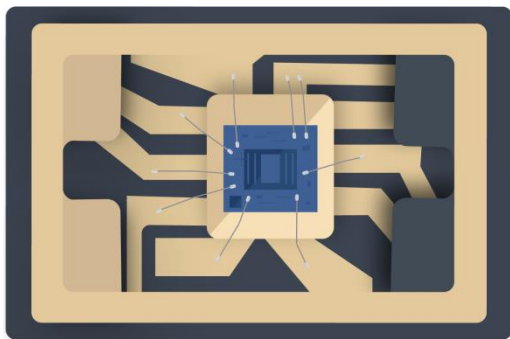

Figure 5c: After de-mounting the quartz crystal, the CMOS IC is revealed underneath.

The ability to fabricate both the timing resonator and the temperature sensor on the same die is possible with silicon MEMS technology.

Co-fabrication of the resonator and temperature sensor is not possible using a conventional quartz crystal assembly process. Packaging, materials, and performance constraints of quartz TCXOs necessitate a large displacement between the crystal and the temperature sensor. The quartz transducer requires meticulous machining, polishing, and trimming of quartz blanks to achieve the desired frequency stability over temperature, while the oscillator circuit, temperature sensor, and compensation circuit on the CMOS IC is manufactured using conventional silicon microfabrication techniques. Integrating these two components that are based on two different material systems poses a number of challenges. The quartz transducer is typically mounted in a ceramic package using a conductive adhesive so that it is suspended in the package cavity with ambient nitrogen gas. The crystal is electrically connected to the CMOS IC, which is mounted at the base of the package, through tungsten vias and gold wire bonds.

Figure 5 shows a) a schematic of the cross-section of an all-in-one quartz oscillator ceramic package, b) a de-capped part with a quartz crystal mounted on the top layer and c) the same part with the quartz crystal removed, revealing the CMOS IC with the temperature sensor, oscillator, and compensation circuitry mounted below the crystal on the base of the package.

MEMS oscillator package construction

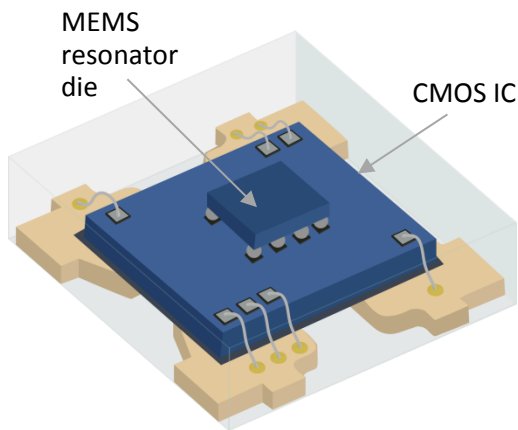

Figure 6: Schematic of SiTime QFN package with the MEMS die mounted directly on top of the CMOS IC.

The Elite Platform DualMEMS does not have this tradeoff. The temperature sensor and the timing resonator are co-located on one die that is mounted directly onto the CMOS IC die as illustrated in Figure 6. Proximity of the MEMS die to the CMOS die and temperature compensation circuitry also ensures tight thermal coupling between these elements.

In summary, Elite Platform Super-TCXOs offer a higher performing, more stable, and more reliable alternative to quartz-based TCXOs in applications that require a precise and stable timing reference. With the DualMEMS architecture and temperature sensing technology, Elite Platform devices sense and compensate for temperature transients much faster than quartz-based TCXOs. The DualMEMS architecture consists of a TempFlat MEMS resonator and a temperature-sensing resonator that are thermally coupled and combined with a proprietary temperature compensation scheme and low-noise frequency synthesizer to enable temperature tracking that is 40 times faster than quartz TCXOs. Together these elements deliver excellent dynamic performance, the ability to maintain <1 ppm frequency stability under environmental stressors such as rapid temperature changes and airflow. These elements also contribute to making the device immune to shock, vibration, and noisy power supplies, and result in reliable performance with exceptional Allan deviation, low jitter, and low phase noise.