

### Features

- Any frequency between 220 MHz and 625 MHz accurate to 6 decimal places
- LVPECL and LVDS output signaling types
- <0.75ps RMS phase jitter (random) over 12 kHz to 20 MHz bandwidth
- Frequency stability as low as ±10 PPM
- Industrial and extended commercial temperature ranges
- Industry-standard packages: 5.0 mm x 3.2 mm and 7.0 mm x 5.0 mm
- For frequencies lower than 220 MHz, refer to SiT9121 datasheet

### Applications

- SONET, Synchronous Ethernet, SATA, SAS, 10GB Ethernet
- Telecom, networking, broadband, instrumentation



### Electrical Characteristics

Parameter and Conditions	Symbol	Min.	Typ.	Max.	Unit	Condition
<b>LVPECL and LVDS, Common AC Characteristics</b>						
Output Frequency Range	f	220	–	625	MHz	For frequency coverage see last page
Frequency Stability	F_stab	-10	–	+10	PPM	Inclusive of initial tolerance, operating temperature, rated power, supply voltage and load variations
		-25	–	+25	PPM	
		-50	–	+50	PPM	
1-year Aging		-1	–	+1	PPM	First year @ 25°C
10-year Aging		-5	–	+5	PPM	@ 85°C
Operating Temperature Range	T_use	-40	–	+85	°C	Industrial
		-20	–	+70	°C	Extended Commercial
Start-up Time	T_start	–	–	10	ms	
Duty Cycle	DC	45	–	55	%	f = 220 to 312.5 MHz and f = 525 to 625 MHz
		40	–	60	%	f = 420 to 500 MHz
<b>LVPECL, DC and AC Characteristics</b>						
Supply Voltage	Vdd	2.97	3.3	3.63	V	
		2.25	2.5	2.75	V	
Current Consumption	Idd	–	61	69	mA	Excluding Load Termination Current, Vdd = 3.3V or 2.5V
OE Disable Supply Current	I_OE	–	–	35	mA	OE = GND
Output Disable Leakage Current	I_leak	–	–	1	µA	OE = GND
Maximum Output Current	I-driver	–	–	30	mA	Maximum average current drawn from OUT+ or OUT-
Output High Voltage	VOH	Vdd-1.1	–	Vdd-0.7	V	See Figure 1
Output Low Voltage	VOL	Vdd-1.9	–	Vdd-1.5	V	See Figure 1
Output differential Voltage Swing	V_Swing	1.2	1.6	2.0	V	See Figure 1
Rise/Fall Time	Tr, Tf	100	300	500	ps	20% to 80%
OE Enable/Disable Time	T_oe	–	–	102	ns	f = 625 MHz - For other frequencies, T_oe = 100ns + 3 period
RMS Period Jitter	T_jitt	–	1.2	1.7	ps	f = 266 MHz, VDD = 3.3V or 2.5V
		–	1.2	1.7	ps	f = 312.5 MHz, VDD = 3.3V or 2.5V
		–	1.2	1.7	ps	f = 622.08 MHz, VDD = 3.3V or 2.5V
RMS Phase Jitter (random)	T_phj	–	0.5	0.75	ps	f = 312.5 MHz, Integration bandwidth = 12 kHz to 20 MHz, all Vdds
<b>LVDS, DC and AC Characteristics</b>						
Supply Voltage	Vdd	2.97	3.3	3.63	V	
		2.25	2.5	2.75	V	
Current Consumption	Idd	–	47	55	mA	Excluding Load Termination Current, Vdd = 3.3V or 2.5V
OE Disable Current	I_OE	–	–	35	mA	OE = Vdd
Output Disable Leakage Current	I_leak	–	–	1	µA	OE = Vdd
Differential Output Voltage	VOD	200	350	500	mV	See Figure 4
VOD Magnitude Change	ΔVOD	–	–	50	mV	See Figure 4
Offset Voltage	VOS	1.125	1.2	1.375	V	See Figure 4
VOS Magnitude Change	ΔVOS	–	–	50	mV	See Figure 4
Rise/Fall Time	Tr, Tf	360	495	600	ps	20% to 80%
OE Enable/Disable Time	T_oe	–	–	102	ns	f = 625 MHz - For other frequencies, T_oe = 100ns + 3 period
RMS Period Jitter	T_jitt	–	1.4	1.7	ps	f = 266 MHz, VDD = 3.3V or 2.5V
		–	1.4	1.7	ps	f = 312.5 MHz, VDD = 3.3V or 2.5V
		–	1.2	1.7	ps	f = 622.08 MHz, VDD = 3.3V or 2.5V
RMS Phase Jitter (random)	T_phj	–	0.5	0.75	ps	f = 312.5 MHz, Integration bandwidth = 12 kHz to 20 MHz, all Vdds

## Pin Description

Pin	Map	Functionality	
1	OE	Input	H or Open: specified frequency output L: output is high impedance
2	NC	NA	Do Not Connect; Leave it floating
3	GND	Power	VDD Power Supply Ground
4	OUT+	Output	Oscillator output
5	OUT-	Output	Complementary oscillator output
6	VDD	Power	Power supply voltage

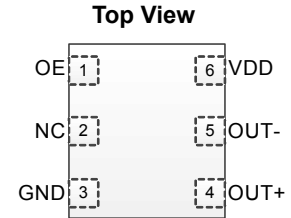

## Absolute Maximum

Attempted operation outside the absolute maximum ratings of the part may cause permanent damage to the part. Actual performance of the IC is only guaranteed within the operational specifications, not at absolute maximum ratings.

Parameter	Min.	Max.	Unit
Storage Temperature	-65	150	°C
VDD	-0.5	4	V
Electrostatic Discharge	–	2000	V
Soldering Temperature (follow standard Pb free soldering guidelines)	–	260	°C
Program Retention over -40 to 125°C, Process, VDD (0 to 3.65V)	1,000+	–	years

## Environmental Compliance

Parameter	Condition/Test Method
Mechanical Shock	MIL-STD-883F, Method 2002
Mechanical Vibration	MIL-STD-883F, Method 2007
Temperature Cycle	JESD22, Method A104
Solderability	MIL-STD-883F, Method 2003
Moisture Sensitivity Level	MSL1 @ 260°C

**Termination Diagrams**

LVPECL:

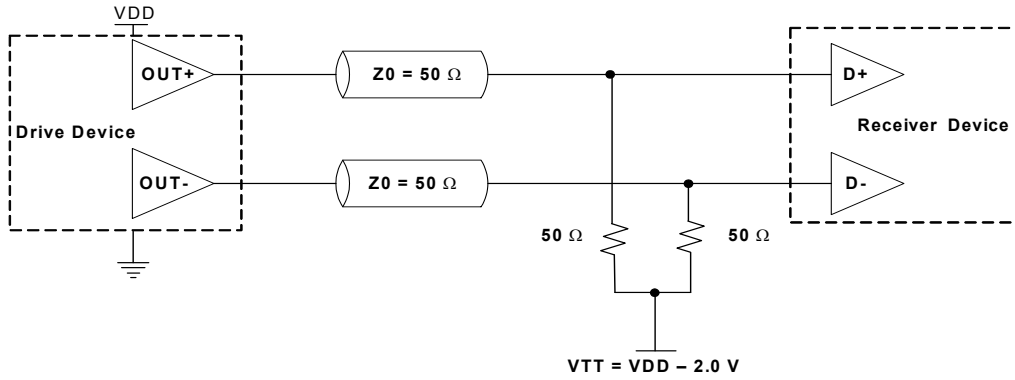

**Figure 1. LVPECL Typical Termination**

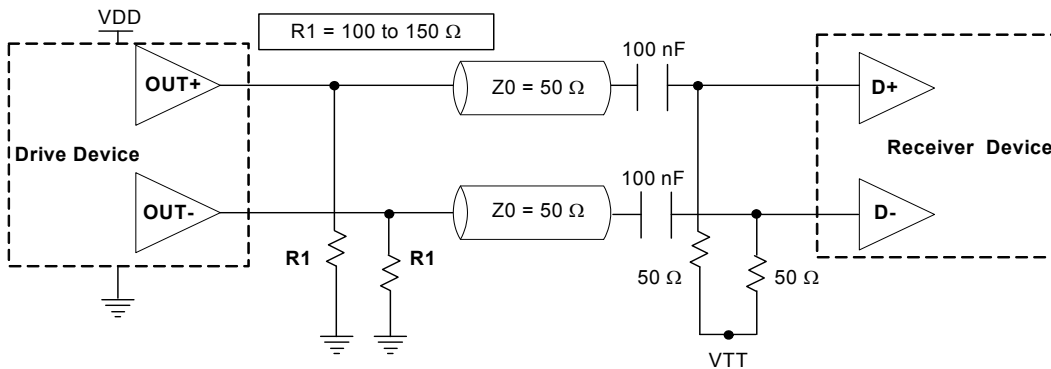

**Figure 2. LVPECL AC Coupled Termination**

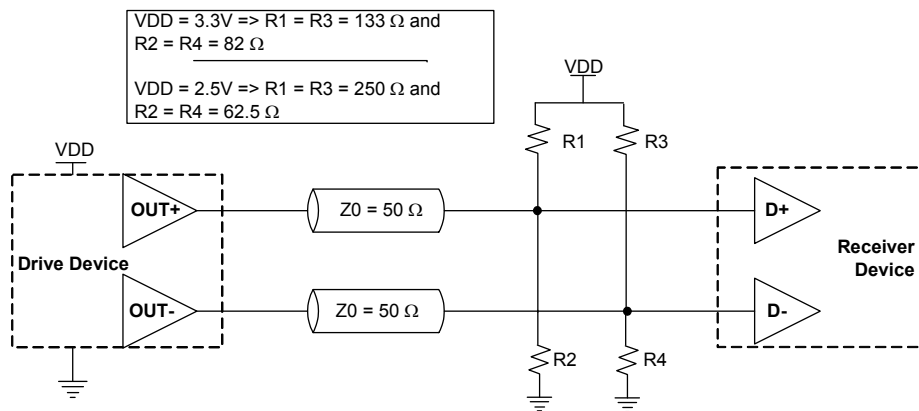

**Figure 3. LVPECL with Thevenin Typical Termination**

LVDS:

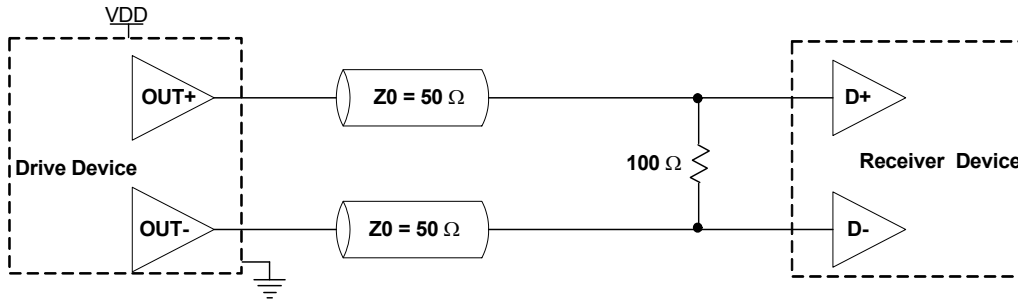
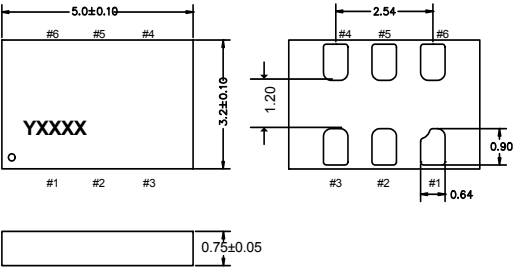
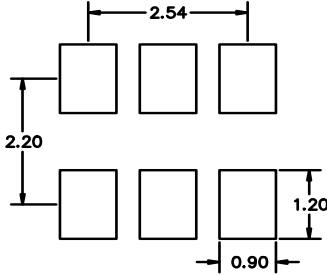
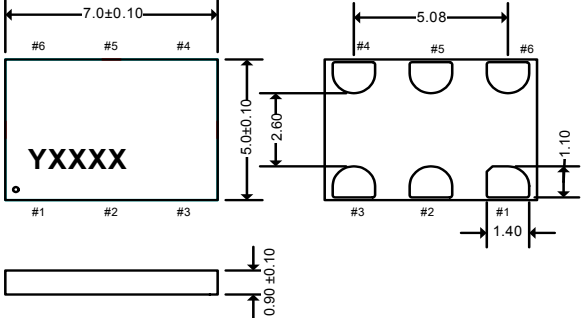
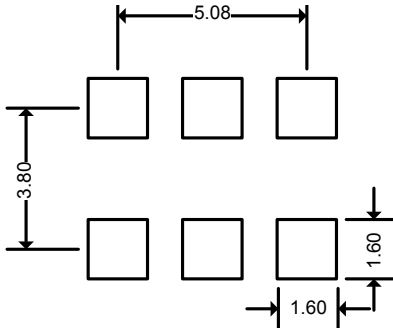

Figure 4. LVDS Single Termination (Load Terminated)

### Dimensions and Patterns

Package Size – Dimensions (Unit: mm) <sup>[1]</sup>	Recommended Land Pattern (Unit: mm) <sup>[2]</sup>
<p><b>5.0 x 3.2 x 0.75 mm</b></p> 	
<p><b>7.0 x 5.0 x 0.90 mm</b></p> 	

1. Top Marking: Y denotes manufacturing origin and XXXX denotes manufacturing lot number. The value of "Y" will depend on the assembly location of the device.
2. A capacitor of value 0.1  $\mu$ F between Vdd and GND is recommended.

### Ordering Information

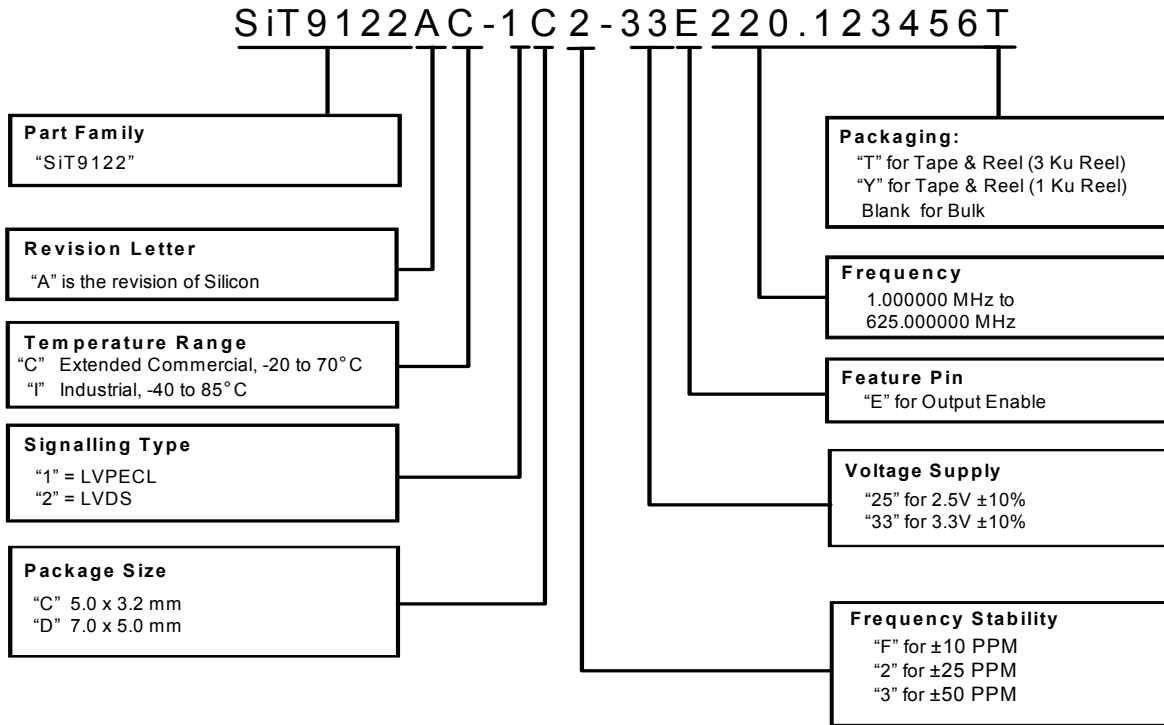

### Frequencies Not Supported

Range 1: From 312.500001 MHz to 419.999999 MHz
Range 2: From 500.000001 MHz to 524.999999 MHz

© SiTime Corporation 2012. The information contained herein is subject to change at any time without notice. SiTime assumes no responsibility or liability for any loss, damage or defect of a Product which is caused in whole or in part by (i) use of any circuitry other than circuitry embodied in a SiTime product, (ii) misuse or abuse including static discharge, neglect or accident, (iii) unauthorized modification or repairs which have been soldered or altered during assembly and are not capable of being tested by SiTime under its normal test conditions, or (iv) improper installation, storage, handling, warehousing or transportation, or (v) being subjected to unusual physical, thermal, or electrical stress.

**Disclaimer:** SiTime makes no warranty of any kind, express or implied, with regard to this material, and specifically disclaims any and all express or implied warranties, either in fact or by operation of law, statutory or otherwise, including the implied warranties of merchantability and fitness for use or a particular purpose, and any implied warranty arising from course of dealing or usage of trade, as well as any common-law duties relating to accuracy or lack of negligence, with respect to this material, any SiTime product and any product documentation. Products sold by SiTime are not suitable or intended to be used in a life support application or component, to operate nuclear facilities, or in other mission critical applications where human life may be involved or at stake. All sales are made conditioned upon compliance with the critical uses policy set forth below.

**CRITICAL USE EXCLUSION POLICY**  
BUYER AGREES NOT TO USE SITIME'S PRODUCTS FOR ANY APPLICATION OR IN ANY COMPONENTS USED IN LIFE SUPPORT DEVICES OR TO OPERATE NUCLEAR FACILITIES OR FOR USE IN OTHER MISSION-CRITICAL APPLICATIONS OR COMPONENTS WHERE HUMAN LIFE OR PROPERTY MAY BE AT STAKE.

SiTime owns all rights, title and interest to the intellectual property related to SiTime's products, including any software, firmware, copyright, patent, or trademark. The sale of SiTime products does not convey or imply any license under patent or other rights. SiTime retains the copyright and trademark rights in all documents, catalogs and plans supplied pursuant to or ancillary to the sale of products or services by SiTime. Unless otherwise agreed to in writing by SiTime, any reproduction, modification, translation, compilation, or representation of this material shall be strictly prohibited.