



SiT8002 Programmable Oscillator:

- One time programmable 1 MHz to 125 MHz
- SG-8002 form and function compatible
- 4 pad QFN-type package
- Excellent frequency accuracy

These highly reliable oscillators are completely Quartz free.



Features

- Frequency range
 - 1 MHz to 125 MHz
- Power down options available
 - Standby
 - Output Enable
- Operating voltage
 - 1.8 V / 2.5 V / 3.3 V
- Frequency tolerance
 - +/- 50 ppm or +/-100 ppm
- World's Smallest Footprints:
 - 2.5 x 2.0 x 0.85 mm
 - 3.2 x 2.5 x 0.85 mm
 - 5.0 x 3.2 x 0.85 mm
 - 7.0 x 5.0 x 0.85 mm
- Operating Temperature Range
 - -40C to +85C
 - -10C to +70C
- Pb free and RoHS compliant QFN SMD packages

Benefits

- Ultra-Reliable start up and greater immunity from interference
- 50,000 G Shock resistance
- 70 G variable frequency mechanical vibration resistance
- Factory programmable for ultra-fast 3 week lead times
- No crystal or capacitors required
 - Eliminates crystal qualification time
 - 50%+ board space saving
- 4 kV ESD protection

Applications

- Audio/Video Players
- Portable Consumer Electronics
- Office Automation: Scanners, Printers, Copiers
- Automotive Applications
- Industrial Applications: Interface Controllers, Graphics Cards

Description

The SiT8002 oscillator family is composed of the world's smallest, high-performance programmable oscillators. The SiT8002 is suitable for use in clock generation for consumer, portable, industrial, automotive, and computation applications.

This oscillator family is packaged in standard low-cost plastic QFN-type IC packages with footprints that match common quartz surface mount products.

MEMS resonators are 1000x smaller by volume than quartz resonators and are built in high volume CMOS fabs instead of small custom manufacturing facilities.

Due to their small size, massive lots sizes, and simpler manufacturing processes MEMS oscillators are inherently more reliable, have more consistent performance and are always in stock.

The SiT8002, by eliminating the quartz crystal, has improved immunity to the environmental effects of vibration, shock, strain, and humidity.

To order samples, go to www.sitime.com and click on the "Request sample" link.

Block Diagram

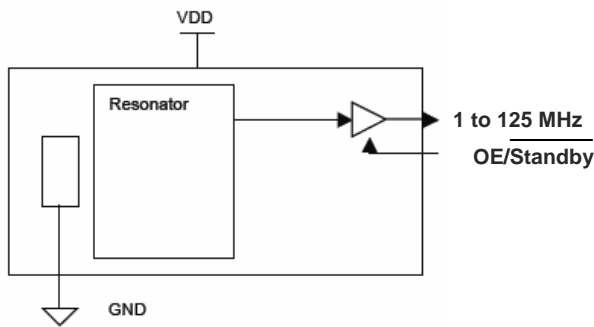

Package Thermal Characteristics

Theta JA = 30°C/W with copper plane on VDD and GND
 Theta JA = 120°C/W with PCB traces of 0.010" to all pins

Pin Description

Pin Number	Pin Name	Pin Type	Pin Description
1	OE/ST	Digital In	Output Enable/Standby
2	GND	Power	Connect to Ground
3	CLK	Digital Out	Clock Output
4	VDD	Power	Connect 1.8V, 2.5V, 3.3V

External Component Selection

Series Termination Resistor

To avoid clock reflections on a 50 ohm PCB trace place a series termination resistor in series with the clock output when the PCB trace is greater than 2 inches. A 33 ohm resistor is usually sufficient. The maximum load capacitance is 15pF.

Decoupling Capacitor

A 0.1uF capacitor is recommended to be placed as close as possible to the VDD GND pins on the part. PCB traces should not be routed through vias. Only one decoupling capacitor is recommended per part.

Absolute Maximum Ratings

Attempted operation outside the absolute maximum ratings of the part may cause permanent damage to the part. Actual performance of the IC is only guaranteed within the operational specifications not absolute maximum ratings.

Parameter	Min	Max	Unit
Storage Temperature	-65	150	°C
Commercial Operation Temperature "C"	-10	70	°C
Industrial Operation Temperature "I"	-40	85	°C
Automotive Operation Temperature (contact SiTime or SiTime sales representative for product in this temperature range)	-40	125	°C
VDD	-0.5	+3.6	V
Electrostatic Discharge, Human Body Model		4000	V
Latch UP per JEDEC 17		200	mA
Output Short Circuit	-40	40	mA

DC Electrical Specifications

The following specification apply at 1.8V +/- 5%, -40 to 85 °C

Parameter	Condition	Min	Typical	Max	Unit
Operating VDD		1.71	1.8	1.89	V
Voltage Output High	$I_{OH} = -10\text{mA}$	70% of Vdd			V
Voltage Output Low	$I_{OL} = 10\text{mA}$			30% of Vdd	V
Operating Current Consumption	at 60 MHz, 15 pF			19	mA
Standby Current Consumption	Output is weakly pulled down		15	20	uA

The following specification apply at 3.3V +/- 10% or 2.5V +/-10%, -40 to 85 °C

Parameter	Condition	Min	Typical	Max	Unit
Operating VDD		2.97	3.3	3.63	V
Operating VDD	2.5V Operation	2.25	2.5	2.75	V
Voltage Output High	$I_{OH} = -25\text{mA}$, Vdd= 3.3V	70% of Vdd			V
Voltage Output High	$I_{OH} = -10\text{mA}$, Vdd= 2.5V	70% of Vdd			V
Voltage Output Low	$I_{OL} = 25\text{mA}$			30% of Vdd	V
Operating Current Consumption	at 60 MHz, 15 pF			19	mA
Power Down Current Consumption			30	50	uA

AC Electrical Specifications

The following specification apply at 3.3V +/- 10%, or 2.5V +/-10%, -40 to 85° C

Parameter	Condition	Min	Typical	Max	Unit
Clock Output Frequency		1		125	MHz
Frequency Drift over temperature	SiT8002Ax-x3-33S-T			+/-50	ppm
	SiT8002Ax-x4-33S-T			+/-100	ppm
Aging	1st year			1	ppm
Clock Output Duty Cycle	Vdd = 3.3V	45	50	55	%
Clock Output Duty Cycle	Vdd = 2.5V	40	50	60	%
Clock Output Rise Time	15 pF			2	ns
Clock Output Fall Time	15 pF			2	ns
Period Jitter pk-pk	At 24 MHz		+/-200		ps
Period Jitter pk-pk	At 100 MHz		+/-100		ps
Start up time			12	50	ms
VDD Ramp Time		0		200	ms

SiT8002AC-14-33S-123.12345T

Part Family: "SiT8002" Revision Letter: "A" is the revision	Temperature Range "C" -10 to 70°C "I" -40 to 85°C	Package Size: "1" 2.5 x 2.0 mm "2" 3.2 x 2.5 mm "3" 5.0 x 3.2 mm "4" 7.0 x 5.0 mm	Frequency Tolerance: "3" +/- 50 ppm "4" +/- 100 ppm	Voltage Supply: "18" 1.8V +/- 0.1V "25" 2.5V +/- 0.2V "33" 3.3V +/- 0.3V	Optional Pin Function: "E" for Output Enable "S" for Standby	Frequency (1 - 125 MHz): e.g. 14.31818 e.g. 125.000	Package: "T" for Tape & Reel
--	--	--	--	--	--	--	---

Package Information

All packages meet:
J-STD-020C for solder reflow and moisture sensitivity

2.5 mm x 2.0 mm x 0.85 mm QFN type package

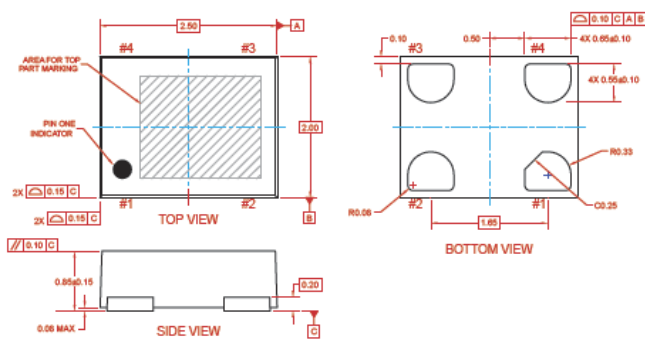

3.2 mm x 2.5 mm x 0.85 mm QFN type package

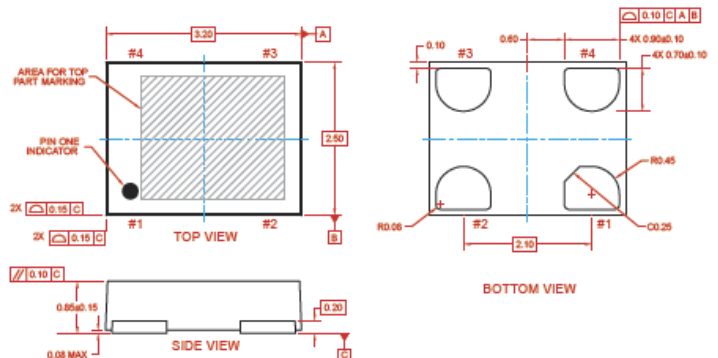

5.0 mm x 3.2 mm x 0.85 mm QFN type package

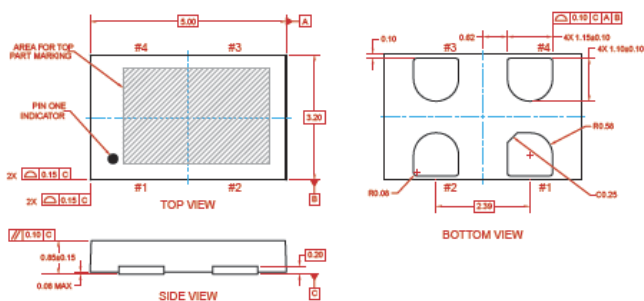

7.0 mm x 5.0 mm x 0.85 mm QFN type package

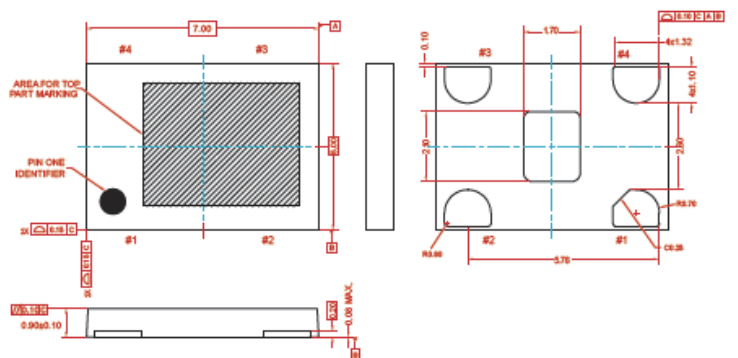

This product and/or its method of use is protected by one or more of the following patent(s): US 7,075,160, US 6,987,432, US 7,071,793, US 7,202,761, US 6,936,491, US 7,068,125, US 6,952,041, US 7,115,436, US 6,995,622, US 7,224,236, US 7,221,230, US 7,102,467, US 7,221,241, US 7,205,867, US 7,227,432, US 6,939,809, US 7,172,917, US 6,936,902, US 5,683,591, US 7,041,225, US 7,259,436, US 6,808,953. Other US and foreign patents pending.