



Features

- Meets or exceeds performance of Epson's SG-8002 family
- Output Enable or Stand By programmable option pin
- One Time Programmable 1 MHz to 125 MHz Clock
- Greater immunity from interference and ultra-reliable start up
- Output driver strength reduces EMI
- RoHS compliant and lead free



SiT8002 Oscillators are suitable for:

- Audio/Video
- Office Automation
- Automotive applications

These highly reliable oscillators are completely quartz free

How to Order - Part Number Guide

SiT8002AX-3X-18X-FFF.FFFFFT

Temperature Range

"C" -10 to 70°C
"I" -40 to 85°C

Frequency Tolerance:

"3" +/-50 ppm
"4" +/-100 ppm

Optional Pin Function:

"E" is Output Enable
"S" is Standby

Frequency (1 - 125 MHz):
e.g. 14.31818
e.g. 125.000

Package:
"T" is Tape & Reel

Specifications

Parameter	Condition	Min	Max	Unit
Output Frequency Range		1	125	MHz
Frequency Tolerance	"3" over temperature, supply voltage, aging		+/-50	ppm
	"4" over temperature, supply voltage, aging		+/-100	ppm
Operating Temperature Range	"C"	-10	70	°C
	"I"	-40	85	°C
Supply Voltage		1.7	1.9	V
Current Consumption	Under 15pF load at 60 MHz		19	mA
Standby Current	Output is Weakly Pulled Down		50	µA
Duty Cycle		40	60	%
Rise/Fall Time			2	ns
Output Voltage-"L"			30	%VDD
Output Voltage-"H"			70	%VDD
Output Load			15	pF
Start Up Time			50	ms
VDD Ramp Time		0	200	ms

Dimensions

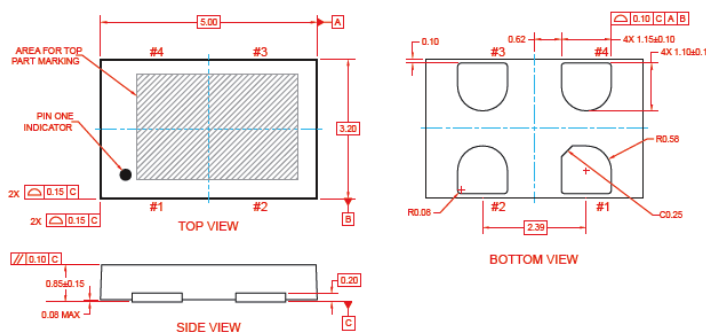

Pin Number	Pin Name	Pin Type	Pin Description
1	ST/OE	Input	Standby, Output Enable
2	GND	Power	Connect to Ground
3	CLK	Output	Clock Output
4	VDD	Power	Connect +1.8V